

Swift M15 Series Compound Microscope

Use and Care Manual

JOIN OUR SOCIAL NETWORK TO WIN!

 Like us on Facebook to enter a drawing for a **FREE** Swift Optical Instruments Lab Manual.*

 Follow us on Twitter for a chance to win a **FREE** Motic digital camera.*

 Join our blog to discover what's happening in the science education industry and enter to win a Starbucks gift card.*

 A smart (phone) way to see us on the web.

*Download free content, eBooks and lab notes on our website.

 **MICROSCOPES & DIGITAL IMAGING PRODUCTS**
Find out more at www.swiftoptical.com



SWIFT M15

Your Swift M15 microscope is an instrument of precision, both optically and mechanically and will last a lifetime with a minimum amount of maintenance. It is built to the highest and most rigid optical and mechanical standards and has many built-in features to insure durability and high performance in the hands of both student and professional users.

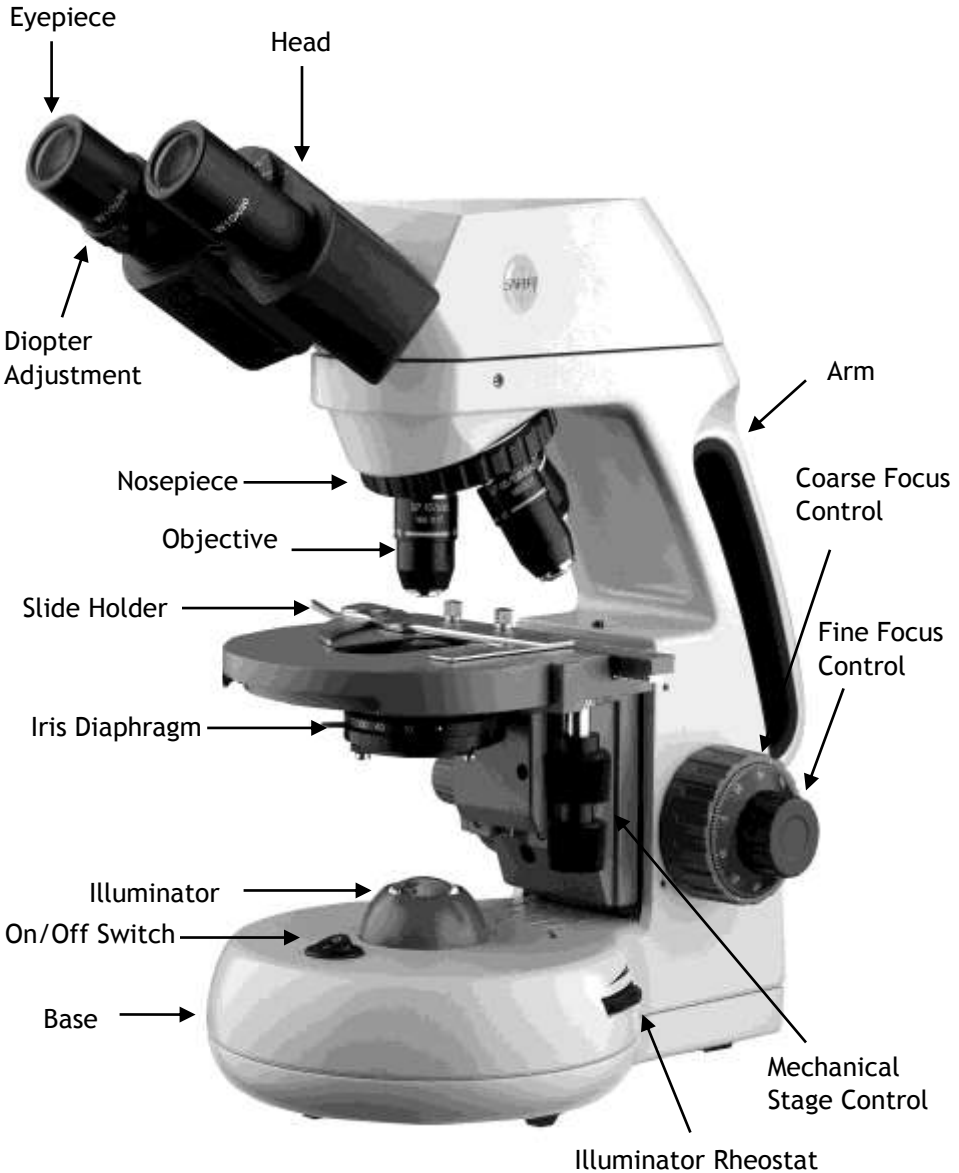

COMPONENTS OF THE MICROSCOPE

ARM – the vertical column (attached to the base) which supports the stage, and contains the coarse and fine adjusting knobs and mechanism.

BASE – the housing and platform of the instrument to which the arm is attached. The base stands on rubber feet and contains the illuminator assembly.

COARSE FOCUS – the larger, outside knob of the focus control which facilitates rapid and heavy movement of the focusing mechanism. In order to prevent gear damage, the focus control is equipped with an upper limit stopper that protects the high magnification objectives and slides.

COAXIAL CONTROLS – the focusing mechanism moves the stage up and down to bring the specimen into focus. The coaxial focusing system combines both the coarse and fine focus into one knob located on both sides of the microscope. The control is designed for a continuous operation over the range of the stage movement. The system is also furnished with a tension control to prevent “stage drift”.

CONDENSER – the function of the condenser is to provide full illumination to the specimen plane and to enhance the resolution and contrast of the object being viewed. The standard condenser of the M15 Series has a numerical aperture of 1.25 with filter carrier and iris diaphragm. It is mounted in a sub-stage focusing assembly that can be raised or lowered for precise light control.

DIOPTER ADJUSTMENT – located on the left eyepiece of the binocular head and is designed to help compensate the difference between the user’s eyes.

EYEPIECES – the upper optical element that further magnifies the primary image of the specimen and brings the light rays in focus at the eye-point.

FINE FOCUS – the smaller inner knobs of the focus control which allows for slow and subtle focusing movement to bring the specimen into sharp focus.

HEAD – the upper portion of the microscope which contains the refracting prisms and the eyepiece tubes which hold the eyepieces.

ILLUMINATION – the built-in light source which provides the optical system with light. The M15 Series uses a variable intensity 6V 20W Halogen.

IRIS DIAPHRAGM – a multi-leaf round shaped device which is controlled by a lever. It is similar to a camera shutter, and is installed under the condenser. By moving the lever back and forth, the iris diaphragm opens and closes, increasing and decreasing the contrast of the specimen. If the image is “washed out” the iris diaphragm is opened too wide. If the image is too dark the iris is not open wide enough.

NOSEPIECE – the revolving turret that holds the objective lenses, permitting changes in magnification by rotating different powered objective lenses into the optical path. The nosepiece must “click” into place for the objectives to be in proper alignment.

OBJECTIVES – the infinity plan optical system which magnifies the primary image of the instrument. Magnifications are typically 4X, 10X, 40X and 100X.

SIEDENTOPF – a binocular head design where the interpupillary adjustment (increasing or decreasing the distance between the eyepieces) is achieved by twisting the eyepiece tubes in an up and down arc motion similar to binoculars.

STAGE – the table of the microscope where the slide is placed for viewing. This component moves upward and downward when the focusing knobs are turned. The stage of the M15 has a built-in mechanical stage with a below-stage ergonomic “X” and “Y” axis controls. A finger clip holds the slide securely and is designed to be a slow return holder to provide protection to the specimen.

IMPORTANT TERMINOLOGY

“COATED” LENS – in attempting to transmit light through glass, much of the light is lost through reflection. Coating a lens increases the light transmission by reducing or eliminating reflection, thus allowing more light to pass through.

COMPOUND MICROSCOPE – a microscope having a primary magnifier (the objective) and a second (the eyepiece) to both conduct light, amplify magnification and convert the image into a field of view easily seen by the human eye.

COVER GLASS – thin glass cut in circles, rectangles, or squares, for covering the specimen (usually a thickness of 0.15 to 0.17mm). The majority of specimens should be protected by a cover glass, and must be covered when using 40XRD or 100XRD objectives.

DEPTH OF FOCUS – the ability of a lens to furnish a distinct image above and below the focal plane. Depth of focus decreases with the increase of numerical aperture or with the increase of magnification.

EYE POINT or EYE RELIEF – the distance from the eye lens of the eyepiece to your eye where a full field of view is seen.

FIELD OF VIEW – the area of the object that is seen when the image is observed. It may range in diameter from several millimeters to less than 0.1mm.

FOCAL LENGTH – parallel rays of light after refraction through a lens will be brought to a focus at the focal point. The distance from the optical center of the lens to the focal point is the focal length.

NUMERICAL APERTURE (NA) – a measure of an objective's light gathering capabilities. The concept may be compared to the F-value in photographic lenses. Generally speaking, N.A. values of less than 1.00 are "Dry" objectives. Values of 1.00 or greater require oil as a medium. Please note that condensers are part of the optical system and are also assigned an N.A. value. That value must be at least as high as that of the highest objective used.

PARFOCAL – a term applied to objectives and eyepieces when practically no change in focus is needed when changing objectives. The objectives on your microscope are parfocaled at the factory so that only a slight adjustment of the fine focus knob is needed to maintain focus when switching magnification.

RESOLUTION or RESOLVING POWER – the ability of a lens to define the details of the specimen at a maximum magnification. This is governed by the NA (Numerical Aperture) of the lens. For example, a 40X objective with NA 0.65 has a maximum resolving power of 650X, equal to 1000 times the NA. This rule of $NA \times 1000$ is true of all achromatic objectives.

WORKING DISTANCE – the distance from the lens of the objective to the cover slip on the slide, when the specimen is in focus.

ASSEMBLY

ASSEMBLY ORDER

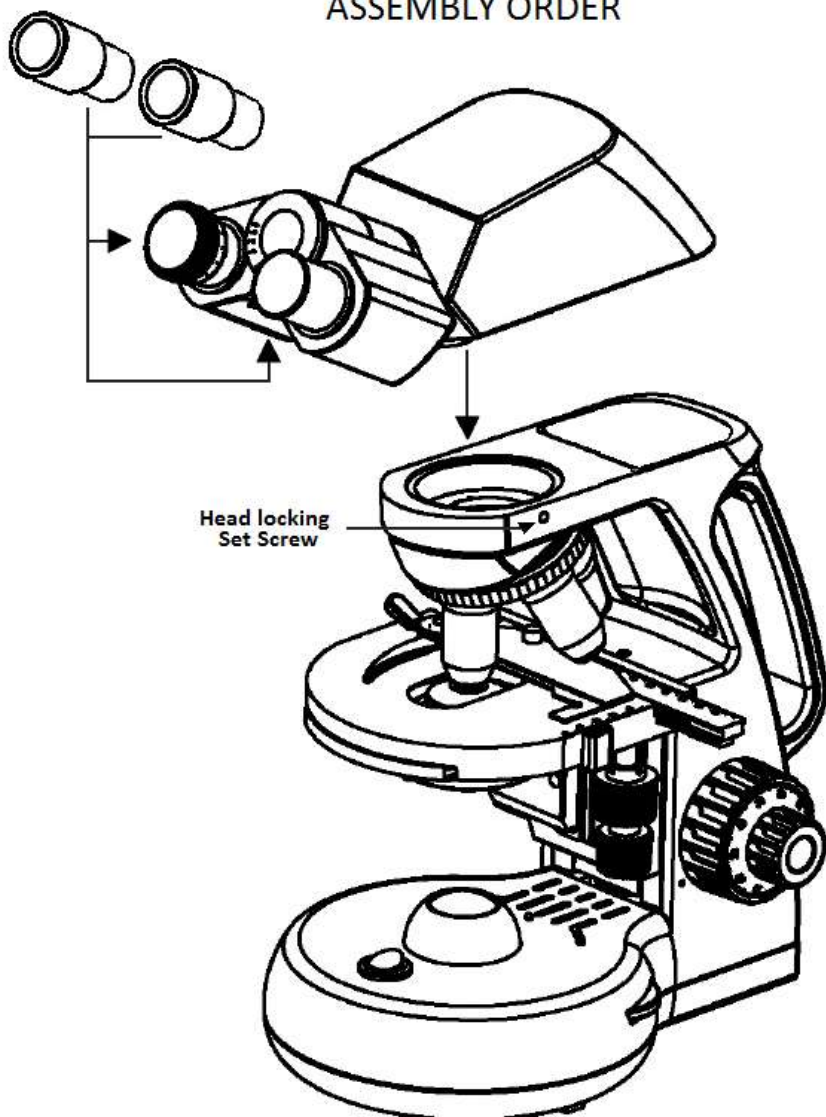

USING THE SWIFT M15 MICROSCOPE

Once you have learned the terminology and purpose of each component of the microscope, use of the microscope is simple. By following these steps, you will be able to begin studying the specimen quickly and easily.

1. Open the slide holder of the mechanical stage and carefully place the slide against the fixed side and back edge of the mechanical stage. Now slowly release the slide holder lever to hold the slide in place.
2. Align the specimen under the objective lens by using the adjustment knobs under the mechanical stage. The bottom knob moves the slide from right/left while the top knob adjusts the slide from front/back. These knobs allow for precise movement and scanning of the slide.
3. Rotate the nosepiece to place the lowest power objective (4XD) over the specimen. Be sure the objective “clicks” into position.
4. Adjust the interpupillary distance of the Siedentopf binocular head for a comfortable view. Align the eyepiece tubes of the binocular head to create one perfect circle, by moving the eyepiece tubes in an arc motion.
5. While viewing through the eyepiece, rotate the coarse focus knob to bring the specimen into focus. This should be done slowly and carefully.
6. To adjust the contrast of the specimen, open the iris diaphragm to its largest aperture. If additional contrast is required to permit accurate viewing of the specimen, the diaphragm should be slowly closed until the details of the specimen are sharply defined. Be careful not to close the aperture too much. Although you may be achieving a higher contrast, the fine structure of the image maybe destroyed. Reducing the aperture increases the contrast and depth of focus, but it also reduces resolution and introduces diffraction. The aperture must be adjusted for each objective.

NA 0.25 for 10XD
NA 0.65 for 40XRD
NA 1.25 for 100XRD

The iris diaphragm is not intended to control the brightness of the illumination, but induce contrast of the specimen by diffracting light rays.

7. Use the fine focus control to complete the focus and produce the sharpest image.

- For additional clarity, use the left eye diopter adjustment to correct the differences between the user's eyes. Set the adjustable left eye diopter at zero. Then focus with the coaxial focusing knob, using your right eye only (close your left eye). Now using your left eye only, adjust the diopter ring until a clear image is seen (close your right eye). The diopter adjustment is now set to the users eyes and will not need to be adjusted again until a different user uses the microscope.
- Now you can rotate the nosepiece to higher magnification objectives. The objectives are parfocaled so that once the lowest objective (4XD) is focused, only a slight turn of the fine focusing knob is required when changing to 10XD, 40XRD and 100XRD objectives.

OIL IMMERSION

It is desirable to use immersion oil with the 100XRD objective. Oil generates a fine resolution and brightness of the image viewed through the microscope. Drop a tiny amount of oil (1 drop) onto the slide prior to focusing with the 100XRD objective (between the slide and the objective tip). It is essential to thoroughly clean the objective tip after use.

IMPORTANT: The focal distance of the 100XRD and 40XRD objective to the slide surface is very close and only the 100XRD objective is sealed to prevent immersion oil contamination, it is a good practice to avoid dragging the 40XRD objective through an oiled slide.

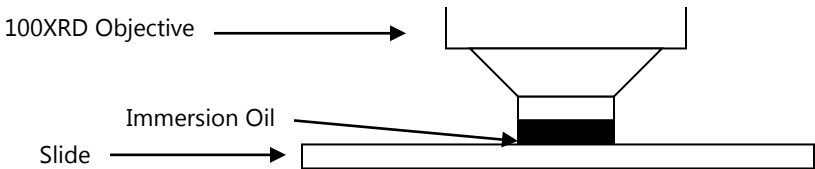

COMMON PROBLEMS IN MICROSCOPY

If you have a problem, you may be able to correct it yourself. Here are a few common problems and easy solutions you may want to try before calling for service.

CAUTION – Never disassemble electrical, mechanical or optical components. This servicing should only be done by an authorized Swift technician. The Limited Lifetime Warranty will be null and void if disassembled by a non-Swift dealer.

A. **PROBLEM** - Image appears “washed out” or weak

CORRECTION -

1. Slowly close the iris diaphragm.
2. Objective lens is dirty. See “Care and Cleaning” Section
3. Eyepiece is dirty. See “Care and Cleaning” Section

B. **PROBLEM** - Hairs or dust seem to be moving in the image

CORRECTION - The iris diaphragm is not open wide enough. Slowly open the iris diaphragm to increase the size of the opening allowing for additional illumination.

C. **PROBLEM** - Unable to bring specimen into focus with any objective

CORRECTION - Eye lens of the eyepiece is partially unscrewed. Remove the eyepiece and screw the two sections together.

D. **PROBLEM** - Image of the specimen goes out of the focus all by itself.

CORRECTION – Increase the focus tension by turning the tension knob found next to the left coarse focus knob.

E. **PROBLEM** – Focusing knobs turn with difficulty even with tension knob loosened.

CORRECTION - Microscope should be disassembled by qualified, authorized repairman, cleaned and re-lubricated.

CARE AND CLEANING

Swift microscopes are designed to function with minimal maintenance, but certain components should be cleaned frequently to ensure ease of viewing. The power switch should be turned off or the microscope should be unplugged when not in use.

CLEANING – The front lens of the objectives (particularly the 40XRD and 100XRD) should be cleaned after use. The lens surface may be gently cleaned with a soft camel hair brush, or blown off with clean, oil-free air to remove dust particles. Then wipe gently with a soft lens tissue, moistened with optical cleaner (eyeglass or camera lens). Immediately dry with a clean lens paper.

CAUTION - Objectives should never be disassembled by the user. If repairs or internal cleaning should be necessary, this should only be done by qualified, authorized microscope technician. The eyepiece(s) may be cleaned in the same manner as the objectives, except in most cases optical cleaner will not be required. In most instances breathing on the eyepiece to moisten the lens and wiping dry with a clean lens tissue is

sufficient to clean the surface. Lenses should never be wiped while dry as this will scratch or otherwise mar the surface of the glass.

The finish of the microscope is hard epoxy and is resistant to acids and reagents. Clean this surface with a damp cloth and mild detergent.

Periodically, the microscope should be disassembled, cleaned and lubricated. This should only be done by a qualified, authorized microscope technician.

DUST COVER AND STORAGE – All microscopes should be protected from dust by a dust cover when in storage or not in use. A dust cover is the most cost-effective microscope insurance you can buy. Ensure that the storage space is tall enough to allow the microscope to be placed into the cabinet or onto a shelf without making undue contact with the eyepieces. Never store microscopes in cabinets containing chemicals which may corrode your microscope. Also, be sure that the objectives are placed in the lowest possible position and the rotating head is turned inward and not protruding from the base. Microscopes with mechanical stages should be adjusted toward the center of the stage to prevent the moveable arms of the mechanical stage from being damaged during storage in the cabinet.

HALOGEN REPLACEMENT

The Swift M15 is equipped with a 6V 20W halogen illumination system. The life of the halogen bulb may vary depending on use and intensity. To prolong the life of the halogen, you should always turn off the unit when not in use.

WARNING: FOR YOUR SAFETY, TURN SWITCH OFF AND REMOVE PLUG FROM POWER SOURCE OUTLET BEFORE MAINTAINING YOUR MICROSCOPE.

- a. Carefully lay instrument on its side, taking care to avoid damage to the specimen slide holder located on top of mechanical stage.
- b. Loosen large chrome locking screw located on hinged door of illuminator base.
- c. Swing door open to expose the halogen lamp.

- d. Using a tissue or cloth to gently grasp the halogen bulb, pull straight out of lamp socket.
- e. Your microscope requires a 6 volt, 20 watt halogen bulb, available from the dealer from which you purchased your microscope. This is a common microscope bulb, Osram "Xenophot HLX #64250 ESB"
- f. Make certain that new bulb is clean, as fingerprints on bulb can affect light transmission. Grasping bulb gently with a tissue or cloth, insert pins straight into lamp socket.
- g. Carefully clean lamp to assure that it is clean and free of all fingerprints.
- h. Close hinged door and tighten locking screw.

SWIFT OPTICAL INSTRUMENTS, INC. LIMITED LIFETIME WARRANTY

Please see our website, www.swiftoptical.com, for complete warranty details and exclusions.

Swift Optical Instruments, Inc. • (877) 967-9438
www.swiftoptical.com

